

Sight Glasses

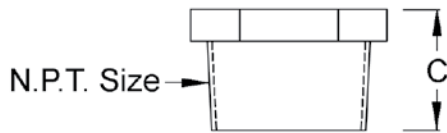

Catalog Number			Dimensions			Thread NPT
Reflex	Clear	Floating Ball	Hex A	B	C	
RL-04	CL-04	FL-04	0.94"	0.56"	0.80"	1/2"
RL-06	CL-06	FL-06	1.06"	0.75"	0.94"	3/4"
RL-08	CL-08	FL-08	1.38"	0.94"	1.06"	1"
RL-10	CL-10	FL-10	1.75"	1.19"	1.22"	1-1/4"
RL-12	CL-12	FL-12	2.00"	1.44"	1.22"	1-1/2"
RL-16	CL-16	FL-16	2.50"	1.88"	1.28"	2"

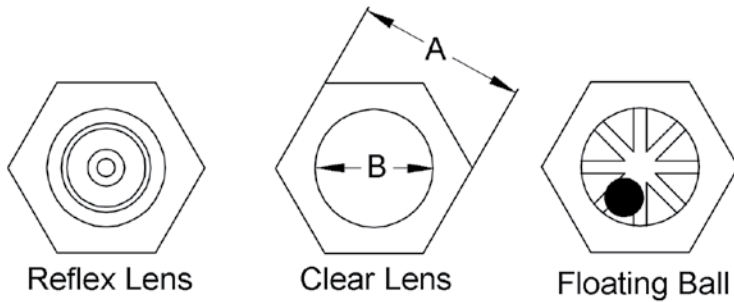
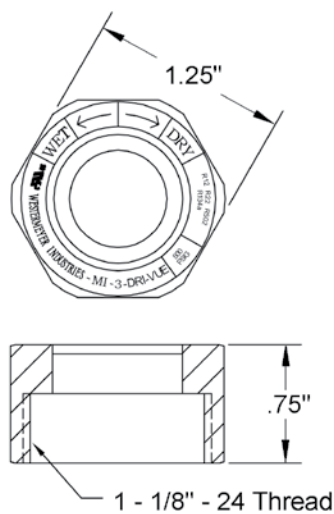

Catalog Number	Dimensions
MI-3B	See figure above.

Sight Glasses

Sight glasses are installed in vessels to view refrigerant, oil and other non-corrosive fluids. Our sight glasses are offered in three versions: reflex, clear lens and floating ball. The RL, reflex lens models, appears dark when liquid is present. When no liquid is present the reflex rings will appear.

All sight glasses are approved up to temperatures of 500°F and they have a maximum working pressure of 500 psig.

Features:

- Hermetically sealed glass
- Nickel plated



Moisture Indicator Sight Glass

Our MI-3B moisture indicator cap is a replacement for existing MI-3B caps that are field installed. Our MI-3B cap includes a Teflon gasket for sealing on the brass housing.

Features

- Nickel plated
- Hermetically sealed glass
- Moisture element protected by filter screen and paper
- Maximum working pressure 500 psig
- Maximum temperature rating 250°F
- Color change from Green (safe) to Yellow (danger)
- Nickel plated

